



## FEATURES

- ¥ Quick loading, self-centering, reel holder.
- ¥ Adjustable bag forming box.
- ¥ Cut-off length adjustment by means of a hand wheel and a mechanical variator.
- ¥ Fin seal folding to the left or to the right.
- ¥ Main drive is a maintenance free, three phases motor, 1 HP, controlled by an AC inverter.
- ¥ Continuous variable speed by means of a potentiometer.
- ¥ PLC controller.
- ¥ In phase machine stop.
- ¥ Digital PID temperature controllers.
- ¥ Maintenance free mercury rotary switches to transfer power to the sealing jaws and fin wheels.
- ¥ Jaws drive torque limiter with safety switch and reset hand wheel.
- ¥ Lugged infeed conveyor equipped with quick release electromagnetic clutch.
- ¥ Discharge belted conveyor.
- ¥ Polycarbonate safety guards with interlock safety switches.
- ¥ Powdered painted steel and anodized aluminum construction.

## OPTIONAL FEATURES

- ¥ Double reel holder.
- ¥ Print registration system.
- ¥ Extended infeed conveyor.
- ¥ Extended exit conveyor.
- ¥ Zigzag cutting knives.
- ¥ Punching displaying holes.
- ¥ Cross-crimping grooves.
- ¥ Multiple cross sealing jaws.
- ¥ Gas flush.
- ¥ Date coders and inline printers.
- ¥ Product detection (no product no bag).
- ¥ Automatic product feeders.
- ¥ For more options contact the factory.

# ARTY 75H

## TECHNICAL DATA ARTY 75H

Bag length*	Min. 1 3/4" (45mm)	Max. 24" (600mm)
Bag width	Min. 1" (25mm)	Max. 7" (175mm) 8" (200mm **)
Reel size	Max width 18" (460mm) Max O.D. 15" (380mm) Core 3" (75mm)	
Speeds up to	Single jaw	125 Bags per minute
	Double jaws	180 Bags per minute
	Quadruple jaws	360 Bags per minute
Power supply	220/10V, single phase	

Specifications are subject to change without notice.

\* The ratio from min. to max. is 1/3.

\*\* With optional 9" wide cross sealing jaws.

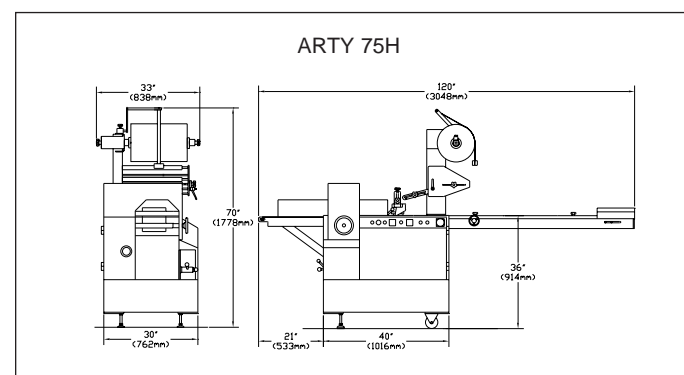

# ARTY 75H

## Performance and Flexibility

« Bells and whistles are optional »

**Compact, easy-to-use  
affordable and  
cost efficient.**

**All contact parts can be  
removed for cleaning with  
no tools required.**

**Electrostatic  
powdered painted  
steel and anodized  
aluminum  
construction with  
stainless steel  
contact parts.**

**One base model  
and many  
attachments to  
cover a wide range  
of applications.**



**Single, double or quadruple  
jaws and many attachments  
to cover a wide variety of  
wrapping applications.**

**Complete line integration**

**Innovative ideas for  
today's changing  
markets.**



- The **ARTY 75H** is a **compact, versatile and easy-to-use flow wrapper** for pillow-pack type applications.
- Built with ingenuity to **cover a wide range of wrapping applications with no change parts needed**. From candies to baked products as well as coupons, products in plastic trays, hardware parts, candy-bars, cookies, pastries, etc.
- Featuring self-centering reel-holder, adjustable bag forming box, telescopic side rails, quick release infeed conveyor and more to achieve **quick set-up and changeovers with no tools and no technical skills required**.
- **Higher speeds (up to 360 bpm with 4 jaws)** than most machines in its price range, using roll stock of plain or printed heat sensitive materials.
- Its **low energy consumption** rate and its **affordable price** places it within the most **economical and cost efficient** machines. (A single jaw machine uses only 1.3 Kilowatt per hour).
- Hinged doors, rotary mercury switches, three phases AC motor, pre-greased sealed bearings are some of the features to **reduce and simplify maintenance**.
- **Improved functionality** by adding optional devices such as: Multiple jaws, extended conveyors, inline printers, hole punches, zigzag knives, automatic feeders, double reel holder, print registration...

**Using the latest technologies, our team of dedicated technicians is creating easy-to-use packaging equipment for the food, drug, chemical and hardware industries, requiring minimal maintenance and no advanced skills to operate.**



*... Simply to run better*